

FREE TRAINING FOR ELIGIBLE MEMBERS



TWU Local 100 - NYC Transit

# TRAINING & UPGRADING FUND

2016 FALL COURSE CATALOG



*Register Now!*

**GREEN**  
CAREER CHOICES

**TECHNICAL**  
COURSES

PROMOTIONAL  
**OPPORTUNITIES**

**EXERCISE & NUTRITION**

*and so much more!*



<b>WORDS FROM THE DIRECTOR</b> .....	3
<b>ELIGIBILITY/REGISTRATION/CALENDAR</b> .....	4-5
<b>NEW JERSEY ONLINE DEFENSIVE DRIVING</b> .....	6
<b>HIGH SCHOOL EQUIVALENCY</b> .....	6
<b>TUITION REIMBURSEMENT</b> .....	7
<b>LANGUAGES</b> .....	8
Spanish	
<b>COMPUTER REPAIR</b> .....	8
A+ Certification	
Networking +	
Hardware 1	
<b>TECHNICAL COURSES</b> .....	9-10
Auto Cad	
Basic Electricity	
Electricity Trouble Shooting	
Electronics 1	
Electronics 2	
Schematics	
<b>GREEN CAREER CHOICES</b> .....	11
Fiber Optics	
Photovoltaics	
<b>PROMOTIONAL OPPORTUNITIES</b> .....	12
Transit Certificate Program	
<b>COLLEGE PREPARATION</b> .....	13
English	
Technical English	
Basic Math	
Technical Math	
<b>COMPUTER SOFTWARE</b> .....	14
Introduction to Computer	
Introduction to Computer with Windows 8	
Microsoft Word	
Microsoft Excel	
<b>GRAPHIC DESIGN</b> .....	15
<b>CIVIL SERVICE TEST PREPARATION</b> .....	16
<b>PROFESSIONAL DEVELOPMENT WORKSHOPS</b> .....	17-18
CPR/First Aid/AED	
Defensive Driving	
Dealing With Difficult People	
Financial Literacy	
Stress Management	
Time Management	
<b>NON-TRADITIONAL EMPLOYMENT FOR WOMEN</b> .....	19
<b>TUTOR.COM</b> .....	20
<b>REGISTRATION FORM</b> .....	21



# Education Is the Key to Success

Charles Jenkins, Acting Director

It gives me great pleasure to be a part of your educational path!

Here starts a great opportunity for you through the TWU Local 100 - NYCT Training & Upgrading Fund (TUF). Our successful Tuition Reimbursement Program has aided members with thousands of dollars toward higher education, being very impactful for members seeking new opportunities within transportation. To learn more about our program, see our flyer on page 7.

Be sure to utilize **Tutor.com** for you and your family. I encourage you to register today and start taking advantage of this household benefit from **Grades K thru College**. Registration is simple, quick and can be done from any computer including your cell phone. If you need assistance, TUF is here to help!

Whether you're looking to promote to the highest level in your department or looking for a career change within NYCT, TUF can get you there. Here at TUF you can also learn new languages, earn your High School Equivalency Diploma or complete your college degree.

Just in case you were wondering which courses would be the best for you, we have highly trained staff that can assist you with choosing the courses that are right for you. We are committed to helping you with your career and keeping up with the ever changing technology in transportation.

Our doors are always open to you. Come visit us at 195 Montague Street, 4th Floor Brooklyn, N.Y. 11201 or call us at (718) 780-8700, Our office hours are 9:00am to 5:00pm.

I look forward to greeting you at the doors to success.

### Mission Statement

The TWU Local 100 - NYCT Training & Upgrading Fund (TUF) will offer continuous education and training to dedicated public transit workers who operate and maintain the largest system in the nation. It aims to enhance individual employability, growth, and opportunity. As the system modernizes, the Fund will help to ensure that workers keep pace with emerging technology. The Fund will give opportunities for workers to remain highly skilled, thus providing the best possible service and maximizing the value of the public investment in transportation.

### Eligibility

Eligibility for TUF benefits depends upon the particular collective bargaining agreement or participation agreement covering your employment.

You are eligible to participate in TUF as soon as you become a Member of TWU Local 100 and an employee of a participating employer.

Limited classes are available for Retirees.

### You are ineligible:

- When you resign or are terminated from your position.
- You are no longer an active member of TWU Local 100.
- Your employer terminates its participation in the Plan.
- The date the Plan is terminated.

### Registration

Every eligible member will have an equal opportunity to register for courses. Enrollment is done on a first come, first served basis for courses listed in this catalog.



#### Phone Registration

Please call 718-780-8700



#### Fax Registration

Fax us at 718-222-1580



#### Email Registration

training@twulocal100tuf.org



#### Walk-in Registration

Hours: 9:00 am to 5:00 pm  
195 Montague Street, 4th Floor,  
Brooklyn, NY 11201.

**Please note that classes may be canceled if enrollment is less than anticipated. All schedules are subject to change. Advance notice will be given.**

### Non-discrimination Policy

TUF admits eligible students of any race, color, national, or ethnic origin to all rights, privileges, and activities generally accorded or made available to members of the Fund. It does not discriminate on the basis of race, color, sexual orientation, national, or ethnic origin in administration of its educational policies, and other Fund administered programs.

# Fall 2016 Holiday Calendar/Schedule

SEPTEMBER						
S	M	T	W	TH	F	S
				1	2	3
4	5	6	7	8	9	10
11	12	13	14	15	16	17
18	19	20	21	22	23	24
25	26	27	28	29	30	

October						
S	M	T	W	TH	F	S
						1
2	3	4	5	6	7	8
9	10	11	12	13	14	15
16	17	18	19	20	21	22
23	24	25	26	27	28	29

November						
S	M	T	W	TH	F	S
		1	2	3	4	5
6	7	8	9	10	11	12
13	14	15	16	17	18	19
20	21	22	23	24	25	26
27	28	29	30			

DECEMBER						
S	M	T	W	TH	F	S
				1	2	3
4	5	6	7	8	9	10
11	12	13	14	15	16	17
18	19	20	21	22	23	24
25	26	27	28	29	30	31



No classes

## Fostering an Environment for Learning

Members who take classes with TUF are hardworking people who are making big commitments to enhance their personal and professional careers. The complete Classroom Rules & Regulations regarding the logistics and what is expected of you during the operation of the course will be distributed at the beginning of each class. Members are also encouraged to remember to show their fellow classmates the respect they deserve by following the rules.

## Class Prerequisites

Some classes will require you to successfully complete a prerequisite class before you are allowed to enroll. Some classes will require you to have minimum reading and math skills before you are allowed to enroll. If necessary, there will be an assessment test given soon after registration. If the class has a required prerequisite, it will be noted within the course description.

## Attendance Policy

Regular attendance is mandatory.

Depending on the length of your class, no more than three (3) absences are allowed for a certificate of completion. If you are more than one (1) hour late to any of your classes, you will be marked absent for the day and it will count towards your total allowed absences for the course.

Attendance requirements will be discussed in further detail in your class.

## Emergency Closings

To find out if classes are canceled in the event of a weather emergency or other unsafe conditions, call 718-780-8700 or check our website at:

**[www.twulocal100tuf.org](http://www.twulocal100tuf.org)** for the latest information or visit us on facebook for the latest information.

**Please make sure TUF has your most current contact information on file.**

## Classroom Locations

**TWU Local 100 - NYCT Training & Upgrading Fund  
195 Montague Street, 4th Floor, Brooklyn, N.Y. 11201**

**1199 SEIU Training Center  
2501 Grand Concourse, Bronx, N.Y. 10468**

**TWU Yonkers Satellite Office  
347 Sawmill River Road, Yonkers, N.Y. 10701**

# New Jersey Online Defensive Driving

## Online Point & Insurance Reduction course

*All Active NJ Licensed TWU Local 100-NYCT*

*Members are eligible to participate!*

- Defensive driving course may be used to remove 2 points from driving records
- Defensive Driving course provides a minimum 5% reduction in the base rate of your liability, no-fault, and collision premiums. Some insurance companies offer more!
- This course is free to Active TWU Local 100 members that are employed by NYC Transit and MaBSTOA.
- Refresh your driving knowledge and receive new tips on driving safely and car maintenance.

**In order to take the class, you must have a valid email address and you must register with TUF before taking this class. TUF will not be responsible for members who take the class on their own without registering with TUF first!**

## High School Equivalency (TASC)

*Formerly the GED Program*



### TEST ASSESSING SECONDARY COMPLETION™

Don't let the new changes to the GED/TASC Program discourage you. If you need to brush up on your computer skills, TUF has classes to help you.

**Please contact TUF at 718-780-8700 if you are interested in enrolling in this course. Enrollment is done on a continuing basis.**

A newly implemented exam called TASC (Test Assessing Secondary Completion) has replaced the GED. Members who began taking the GED test but did not complete all 5 modules will be required to take the TASC test.

#### **Some of the major changes to the test are:**

- The test will be done on a computer.
- No writing utensils or hand-held calculators will be allowed into the test.
- The test will consist of five modules which are: Math, Reading, Writing, Science, and Social Studies.
- Test takers will receive detailed score reports in each area describing areas of mastery and/or areas in need of improvement.



# Education College University Trade School

**TWU LOCAL 100 NYCT TRAINING AND UPGRADING  
FUND WANTS MEMBERS TO KNOW...**

# TUITION REIMBURSEMENT

**is now available for all active  
T.A. and O.A. employees**

***Tuition Reimbursement is on a first come, first served basis.***

**Apply online at [www.twulocal100tuf.org](http://www.twulocal100tuf.org)**



TWU Local 100 - NYC Transit  
**TRAINING &  
UPGRADING FUND**

**TWU Local 100 - NYCT Training & Upgrading Fund**  
195 Montague Street, 4th Floor Brooklyn, N.Y. 11201  
Phone: 718-780-8700 • Fax: 718-222-1580 • Email: [training@twulocal100tuf.org](mailto:training@twulocal100tuf.org)  
Website: [www.twulocal100tuf.org](http://www.twulocal100tuf.org) • Charles Jenkins, Acting Director  
**MUST BE IN GOOD STANDING!!!**

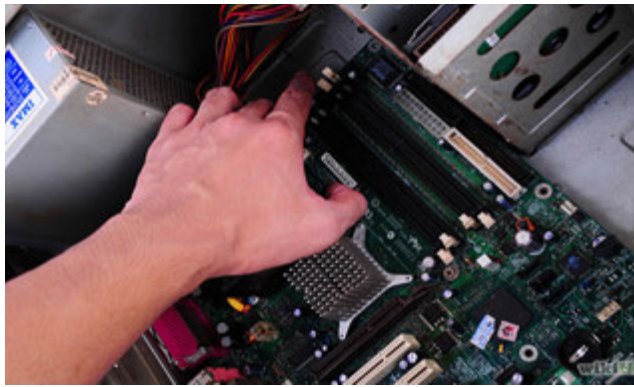

## Hardware 1

This course will introduce members to the basics of computer repair. Individually, members will take apart and put together computers, install, and upgrade the operating system, analyze and clean-up the hard drive, and set up a simple network.

**Saturdays**  
**9:30am-12:30pm**  
**10/8/16 to 12/10/16**

**Wednesdays**  
**5:30pm-8:30pm**  
**10/5/16 to 12/14/16**



## A+ Certification

This class will cover the fundamentals of computer technology, installation and configuration of PCs, laptops and related hardware, and basic networking. It will also cover the skills required to install and configure PC operating systems, as well as configuring common features (e.g. network connectivity and email) for mobile operating systems. After successfully passing the exam, members will earn a certification that is nationally recognized.

**\*Prerequisite required:**  
**Computer Hardware 2**

**Tuesdays, 5:30pm to 8:30pm**  
**9/27/16 to 12/13/16**

**Wednesdays, 9:30am to 12:30pm**  
**9/28/16 to 12/21/16**

## Network + Certification

This course will cover network technologies, installation & configuration, media and topologies, management, security, and troubleshooting. After successfully passing the exam, members will earn a certification that is nationally recognized.

**\*Pre-requisite required:**  
**Computer Hardware 2**

**Thursdays, 5:30pm to 8:30pm**  
**9/29/16 to 12/22/16**



## Electronics 1

You will learn the basic fundamentals of electronics terminology and mathematical formulas which allow you to advance into other technical courses. Course content includes but is not limited to: Basic Electricity, D.C. and A.C. Electronics Theory, Semiconductor Theory, and Solid State Theory.

**\*A Math Assessment test is required prior to the start of class. If you do not pass the test, you are required to take a basic math or technical math course before you can enter the electronics course. Contact TUF to schedule your test before arriving.**

**Math Assessment Schedule:**  
**Monday through Thursday: 9:00am to 7:00pm**  
**Friday: 9:00am to 4:00pm**  
**Saturday: Call for availability**

**Class Schedule:**  
**Mondays & Tuesdays, 5:30pm to 8:30pm**  
**9/12/16 to 11/22/16**

**Tuesdays & Wednesdays, 1:00pm to 4:00pm**  
**9/6/16 to 11/16/16**

**Wednesdays & Thursdays, 9:30am to 12:30pm**  
**9/7/16 to 11/17/16**

Dates and times are subject to change



## Basic Electricity

Students will learn Basic Electricity Principles, how to understand Electrical Circuits, how to understand electrical drawings and symbols, generators and transformers, electric motors, electrical protection, and industrial electrical wiring. In addition, they will learn about high voltage electrical safety.

**Mondays, 9:30am to 12:30pm**  
**9/12/16 to 11/21/16**

**Tuesdays, 5:30pm to 8:30pm**  
**9/13/16 to 11/22/16**

**Saturdays, 9:30am-12:30pm**  
**9/10/16 to 11/12/16**

## Electricity-Trouble Shooting

Students will learn Electrical Safety Requirements during System installation and equipment maintenance, testing procedures, Electrical testing on low voltage equipment, medium voltage equipment troubleshooting, remote instrumentation and on-line monitoring systems, grounding system maintenance and testing requirements, high voltage testing and troubleshooting, and power transformer troubleshooting.

**\*Prerequisite Required: Basic Electricity**

**Mondays, 9:30am to 12:30pm**  
**11/28/16 to 12/19/16**

**Tuesdays, 5:30pm-8:30pm**  
**11/29/16-12/20/16**

**Saturdays, 9:30am to 12:30pm**  
**11/19/16 to 12/17/16**

## Electronics 2

You will build electronic projects with real electronic components. Each member will need to use the electronics theory that was applied in Electronics 1 and identify electronics components to complete each electronics project. Course contents include but is not limited to: Safety, Electronics Components Identification and Testing, and Project Board Writing.

**\*Prerequisite Required: Electronics 1**

**Mondays, 9:30am to 12:30pm**  
**9/12/16 to 11/14/16**

**Wednesdays, 5:30pm to 8:30pm**  
**9/7/16 to 11/9/16**

Dates and times are subject to change

## Schematics

In this class you will learn to identify the symbols that are schematically and pictorially used to represent various electrical components in an electrical circuit. You will learn how to accurately read and trace out simple and complex schematic circuits. You will be able to apply your knowledge of electrical and electronics theory to make use of schematics and wire diagrams to perform basic troubleshooting skills.

**Mondays, 1:00pm to 4:00pm, 9/12/16 to 11/14/16**

**Tuesdays, 9:30am to 12:30pm, 9/13/16 to 11/15/16**

**Thursdays, 5:30pm to 8:30pm, 9/8/16 to 11/10/16**

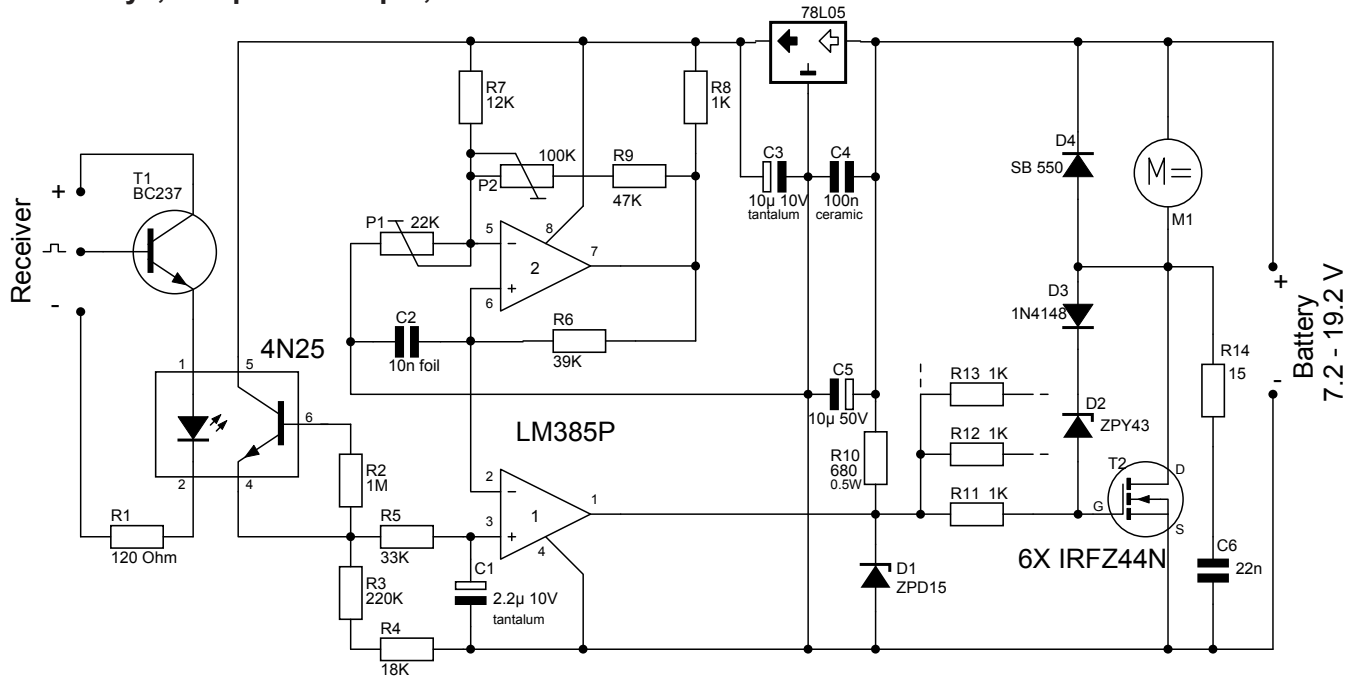

## Auto-Cad 2016

Auto-Cad is a computer-aided design and drafting software. This course will allow members to create two and three dimensional prototypes using step by step instruction and hands-on projects based on real-world designs. Topics will include the Auto-Cad drawing interface, display commands, CAD tools, and so much more! Members will master these concepts through the creation of a variety of 2d technical drawings. Must have working knowledge of computers.

**Mondays, 9:30am to 12:30pm, 9/12/16 to 12/19/16**

**Wednesdays, 5:30pm to 8:30pm, 9/14/16 to 12/14/16**





## Photovoltaics

This course will introduce members to Photovoltaics component theory, system design, industry codes and standards, for Photovoltaics systems, and unique design problems and solutions.

**\*Prerequisites required: Electronics 1**

Tuesdays, 9:30am to 12:30pm, 9/27/16 to 11/29/16

Thursdays, 5:30pm to 8:30pm, 9/29/16 to 12/8/16

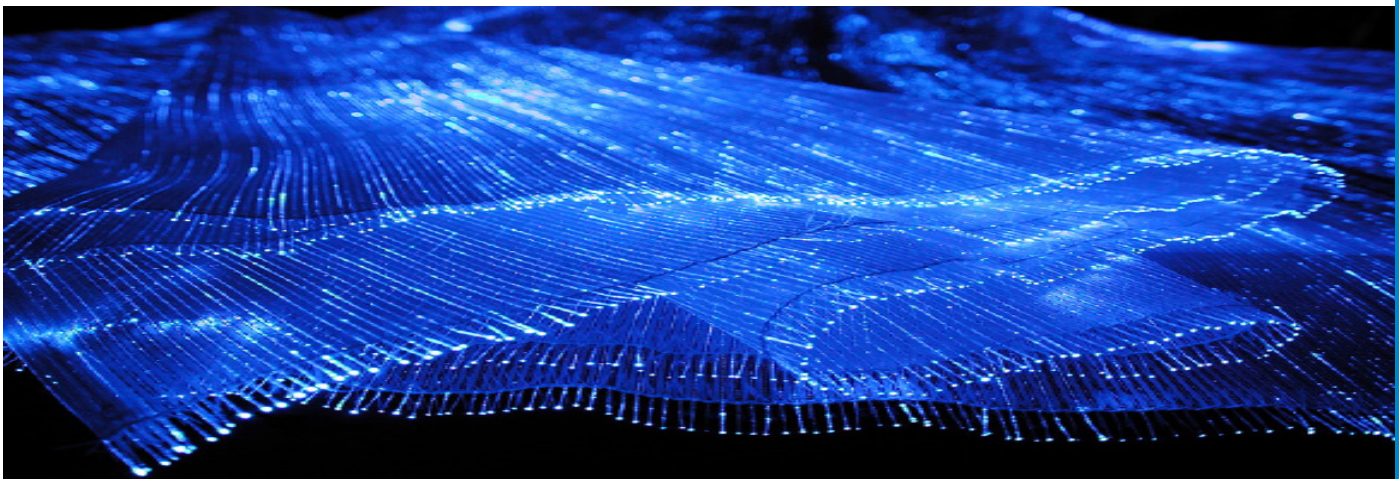

## Fiber Optics

This introductory Fiber Optics course is designed for anyone interested in learning basic fiber optic networking. This program combines theory and hands-on activities to prepare the students to take the CFOT (Certified Fiber Optics Technician) test. This course also introduces the student to industry standards, and further introduces the student to basic fusion and mechanical splicing. Anyone interested in becoming a Certified Fiber Optics Technician should attend this class.

**\*Prerequisite required:**

**Electronics 1 or must have electronic knowledge and pass an assessment test.**

Monday through Friday, 9:30am to 1:30pm, 9/12/16 to 9/23/16

Monday through Friday, 5:00pm to 9:00pm, 9/12/16 to 9/23/16

Dates and times are subject to change

Are you a Transit Property Protection Agent, Cleaner, or Station Agent looking to advance your career to Train Operator?



## TRANSIT CERTIFICATE PROGRAM (TCP)

If so, the Transit Certificate Program is just for you. Members in entry level titles are now able to broaden their promotional opportunities. TCP gives members the background information they need to prepare for promotional exams in operational titles such as Train Operator.

**TCP consists of three core courses and they are as follows:**

- Worker, Health, & Safety (3 College Credits)\*
- An Overview of Transit (3 College Credits)\*
- Job Duties of a Train Operator

Successful completion of all three courses will make Civil Service members eligible to take the promotional exam for the Train Operator title. In addition, members can earn up to **6 college credits** and can use them towards obtaining their degree.\*\*

### Information Sessions:

<b>Monday</b>	<b>10:00am - 12:00pm</b>	<b>10/31/16</b>
<b>Wednesday</b>	<b>5:00pm - 7:00pm</b>	<b>11/2/16</b>
<b>Tuesday</b>	<b>10:00am - 12:00pm</b>	<b>11/8/16</b>
<b>Thursday</b>	<b>5:00pm - 7:00pm</b>	<b>11/10/16</b>

*\*You will be required to take a TABE assessment test prior to entering these courses.*

*\*\*Please check with your school to make sure they will accept these credits.*

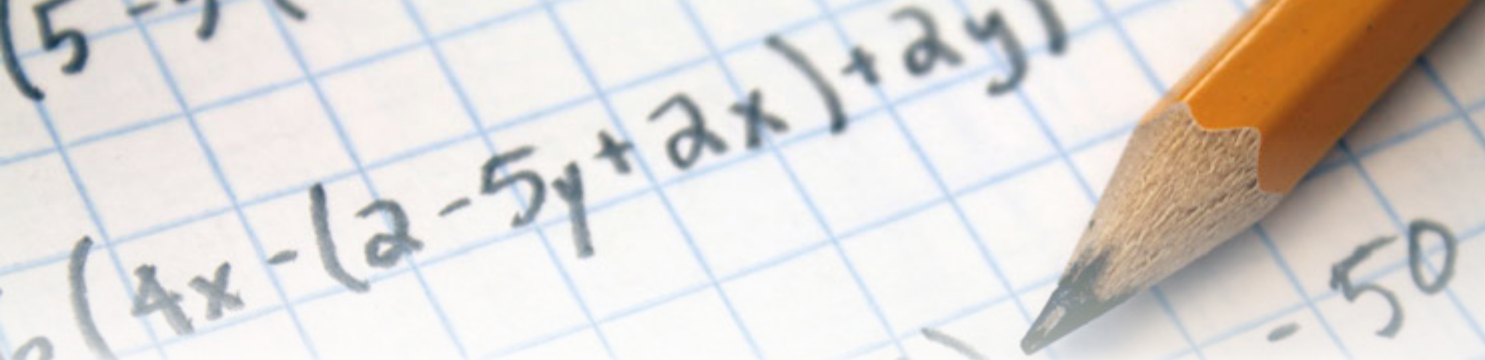

TWU LOCAL 100 - NYCT Training & Upgrading Fund believes in empowering our members with the academic skills necessary to excel in college and in our competitive workforce. The mission of TUF College Prep is to help our members develop themselves as leaders through a rigorous college prep course that focuses on college level readiness. Our classes are designed to help you enter college and to succeed. We have classes in English, Math and Writing to jump start your college experience.

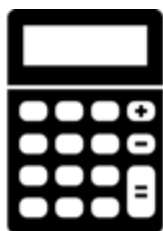

### Basic Math

Basic Math will prepare members for the Transit Certificate Program (TCP) and college level courses. Topics include: basic math, scientific measurements, and algebra.

**Mondays, 5:30pm to 8:30pm**  
9/12/16 to 12/19/16

**Wednesdays, 9:30am to 12:30pm**  
9/7/16 to 1/4/17



### Technical Math

This course is designed to prepare members to understand the mathematics terminology in electronics and/or electrical. This course can also help members prepare for any Civil Service exam. Topics include: decimals and fractions, ratios and proportions, unit conversions, area and volumes, application of algebraic equations in Ohm's and Kirchhoff's laws, solving for circuit resistance and reactions, relevant trigonometric functions, and use of graphs to analyze data.

**Mondays, 9:30am to 12:30pm**  
9/12/16 to 12/19/16

**Thursdays, 5:30pm to 8:30pm**  
9/8/16 to 12/22/16



### English

English will provide a basic review of remedial English including grammar, sentence structure, punctuation, paragraph development, writing, etc. Members will complete many practice exercises, including writing paragraphs.

**Mondays, 5:30pm to 8:30pm**  
9/12/16 to 12/19/16

**Thursdays, 9:30am to 12:30pm**  
9/8/16 to 1/5/17

### Intro to Spanish Level 1

**Mondays, 5:30pm to 8:30pm**  
10/3/16 to 12/12/16

**Wednesdays, 9:30am to 12:30pm**  
10/5/16 to 12/14/16

## Introduction to Computers with Windows 10

This course focuses on the basics of the Introduction to Computers course, as well as introduces you to the new operating system of Windows 10. Come learn how to navigate and learn the new capabilities of the new Windows 10 user interface. Through hands-on practice, learn how to customize, navigate, explore, and utilize a Windows 10 operating system.

**Tuesdays, 5:30pm to 8:30pm**  
10/11/16 to 12/6/16

**Thursdays, 1:00pm to 4:00pm**  
10/6/16 to 12/15/16

**Saturdays, 9:30am to 12:30pm**  
10/1/16 to 12/17/16

## Computer Integration

Today's technology has had an explosive growth in mobile and tablet devices. Mobile and Tablet devices play an essential role in both our personal and professional life. Most people rely on technology to help them operate more efficiently and effectively. TUF has a course that can help members to utilize their smart phone or tablet like a Personal Computer on the Android and/or IOS(Apple) Operating system. You will learn how to navigate keys, sync email and social networks, print and email documents, and set up Wi-Fi.



**Android**  
**Saturday, 10:00am - 1:00pm, 9/24/16**  
**Tuesday, 5:30pm - 8:30pm, 10/18/16**  
**Saturday, 10:00am - 1:00pm, 12/3/16**



**Apple**  
**Monday, 5:30pm - 8:30pm, 9/26/16**  
**Saturday, 10:00am - 1:00pm, 10/29/16**  
**Saturday, 10:00am - 1:00pm, 12/17/16**

## Introduction to Computers in the Bronx

Come learn the basics of the computer. You will learn the best ways to navigate, organize, and manage your computer and its contents. You will identify parts of the computer and how they work, then move on to using basic programs and the Internet.

**Tuesdays, 5:30pm to 8:30pm**  
10/11/16 to 12/6/16

**Saturdays, 9:30am to 12:30pm**  
10/1/16 to 12/17/16



## Microsoft Word

Turn boring documents into must-read material. You will learn how to create professional documents such as letters, reports, memos, etc., through formatting tools, themes, designs, and sharing features.

**Mondays, 5:30pm to 8:30pm**  
10/3/16 to 12/12/16

**Thursdays, 9:30am to 12:30pm**  
10/6/16 to 12/15/16



## Microsoft Excel

Turn unorganized data into useful information. Excel is Microsoft's popular spreadsheet application. Topics include entering data and formulas, moving and copying data, formatting and print previewing worksheets.

**Wednesdays, 5:30pm to 8:30pm**  
10/5/16 to 12/14/16

**Fridays, 9:30am to 12:30pm**  
10/7/16 to 12/23/16



## Microsoft Access

This course teaches members how to design and create databases. Members explore the program and learn essential skills such as finding and using database templates, creating tables, and modifying forms and reports.

**Thursdays, 9:30am to 12:30pm**  
**10/6/16 to 12/15/16**



## Microsoft Publisher

In this Microsoft Publisher course, members will learn to use this desktop publishing software application that is capable of producing flyers, certificates, newsletters, and other printed publications. Publisher offers a large selection of “building blocks” that can be dragged into your documents, helping you to create page elements such as calendars, newsletter sidebars, and borders.

**Tuesdays, 5:30pm to 8:30pm**  
**10/11/16 to 12/6/16**

# GRAPHIC DESIGN

## *With Corel Drawing*

Have you ever wanted to say something but didn't know how to say it clearly enough to get your point across? In this graphic design class you will learn how to visually communicate your thoughts to your coworkers, friends, and family.

You will learn:

- **Mechanics of type composition**
- **Fundamentals of layouts**
- **Concept of color imaging**

By the end of the class you will be able to create eye popping flyers and brochures that not only look awesome but communicates your message.

**Tuesdays, 9:30am to 12:30pm**  
**10/11/16 to 12/6/16**

**Thursdays, 5:30pm to 8:30pm**  
**10/6/16 to 12/15/16**

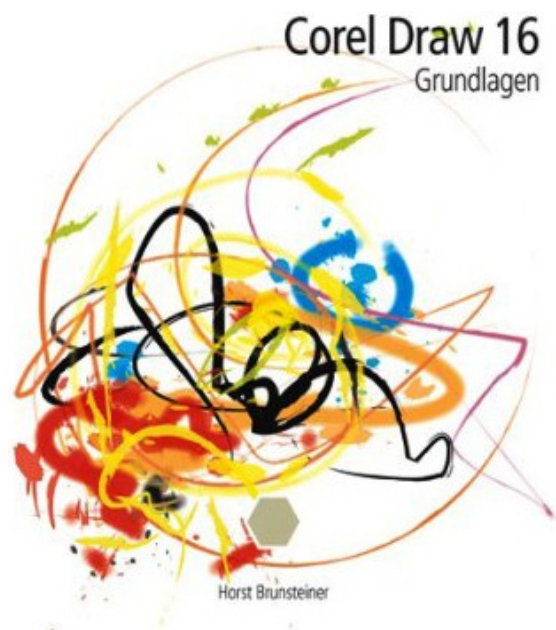

Dates and times are subject to change



## Civil Service Test Prep

Have you filed for the Car Inspector Exam but feel that you need to brush up on your test taking skills? Maybe your Train Operator Exam is approaching and you would like to know a little more about the job? Our new hands-on laboratory can help you accomplish that and more! Prep courses are given for promotional exams that are within the TWU Local 100 Collective Bargaining Unit. Below is a list of exams that will be open for filing as posted on the MTA website. Please call the Fund to inquire about Prep courses for any upcoming promotional exams.

Agency	Exam Title	Exam No.	Application Period
NYC Transit	Signal Maintainer	7601	Aug.5-23,2016
NYC Transit	Promotion to Signal Maintainer	7700	Sept. 9-27, 2016
NYC Transit	Electronic Equipment Maintainer	7603	Sept. 9-27, 2016
NTC Transit	Promotion to Electronic Equipment Maintainer	7703	Oct. 7-25, 2016
NYC Transit	Bus Maintainer Chassis	7102	Nov. 4-22, 2016

**\* The above information was obtained from the MTA website and is current as of 7/15/16. Please check the MTA's website for any updates or changes at <http://web.mta.info/nyct/hr/appexam.htm>.**



## Refresher Courses

Technology is constantly changing and it's always a good move to stay on track with it. TUF can assist you with that! Our refresher courses will be geared towards:

- Assisting members in updating their current skills
- Introducing new technology that affects current represented titles
- Training members to advance in their career or to prepare for new opportunities

All training will take place in TUF's new practical lab. Call TUF to inquire about upcoming Refresher Courses. The lab is constantly being updated so come check it out!



## New York Defensive Driving

### 6-Hours Point and Insurance Reduction Course



All Active TWU Local 100 Brothers and Sisters are eligible.

**\*\$20.00 Fee for MTA Bus, Private Lines, Retirees and Spouses**

- Refresh your driving knowledge with a review of time-tested safe driving tips and an overview of today's New York State vehicle and traffic laws.
- Eligibility to reduce as many as four (4) points on your driving record.
- Receive a minimum 10% reduction in the base rate of your automobile and motorcycle liability and collision insurance each year for three years.

Day (s)	Time (s)	Date (s)
Wednesday	10:00am - 4:00pm	9/7/2016
Thurs/Friday	9:00am - 12:00pm	9/8/16-9/9/16
Saturday	10:00am - 4:00pm	9/10/16
Mon/Tuesday	5:00pm - 8:00pm	9/12/16-9/13/16
Wednesday	10:00am - 4:00pm	10/5/16
Thurs/Friday	9:00am - 12:00pm	10/6/16-10/7/16
Saturday	10:00am - 4:00pm	10/8/16
Mon/Tuesday	5:00pm - 8:00pm	10/17/16-10/18/16
Wednesday	10:00am - 4:00pm	11/2/16
Thurs/Friday	9:00am - 12:00pm	11/3/16-11/4/16
Saturday	10:00am - 4:00pm	11/5/16
Mon/Tuesday	5:00pm - 8:00pm	11/7/16-11/8/16
Thurs/Friday	9:00am - 12:00pm	12/1/16-12/2/16
Saturday	10:00am - 4:00pm	12/3/16
Mon/Tuesday	5:00pm - 8:00pm	12/5/16-12/6/16
Wednesday	10:00am - 4:00pm	12/7/16

## CPR/First Aid/AED

Our hands-on CPR/First Aid/AED course will prepare you to respond to a variety of emergencies for adults and children through lectures, interactive videos, emergency scenarios, and hands-on training.

### You will learn to:

- Call for and work with EMS.
- Care for a variety of emergencies such as burns, cuts and scrapes, sudden illness, head, neck, and back injuries, etc.
- Care for conscious and unconscious victims.
- Perform CPR and care for breathing and cardiac emergencies in adults and children.
- Learn how to use automatic external defibrillators.
- Gain confidence to act quickly and effectively in the face of an emergency.



**Saturday, 10:00am - 4:00pm, 9/24/16**  
**Saturday, 10:00am - 4:00pm, 10/22/16**  
**Saturday, 10:00am - 4:00pm, 11/19/16**  
**Saturday, 10:00am - 4:00pm, 12/10/16**

Once the course is completed you will receive a CPR/First Aid/AED certification.

**You should get re-certified every two years.**

Dates and times are subject to change



## **Financial Literacy**

Isn't it time to make your money work for you?

These workshops are for members who want to understand how money works, how to plan for their financial future, and secure their life goals and dreams.

Learn how to manage your finances and credit score.

## **Taxes and Tax Credit**

## **Psychology of Money/Behavioral Finance**

## **Credit, Credit Reports and Debt**

## **Investments, Insurance, and Retirement Planning**

Are you interested in managing your time/stress and how to deal with difficult people?



Would you like to improve on your customer service skills?

If so, we have the perfect workshops for you!

## **Time Management**

Members will learn techniques on how to manage time more efficiently and effectively.

## **Stress Management**

Members will learn strategies and techniques on how to deal with stressful situations.

## **Dealing with Difficult People**

Members will learn concrete techniques for dealing with difficult people in and out of the workplace. Learn how to get chronic complainers to quiet down and difficult people to cooperate.

Call us at 718-780-8700 today!

Dates and times to be announced

# TUF is Looking For A Few Good Women

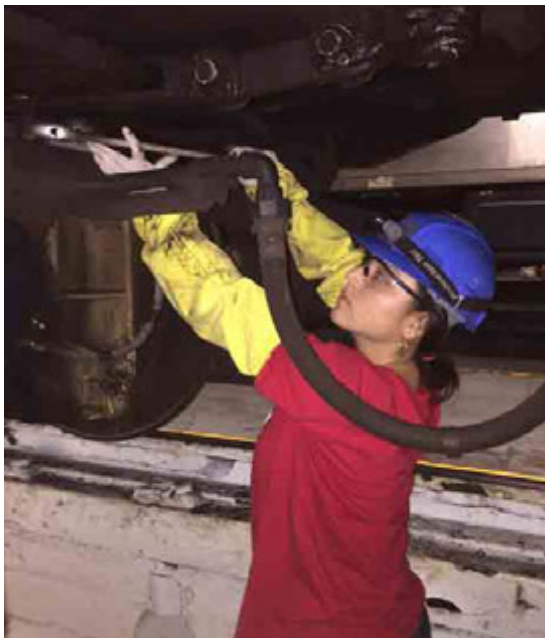

## Introduction to Trades for Women Workshop

Introduction to Trades for Women Workshop prepares women to make decisions about their career path. Women will try their hand at a number of different trades in order to better understand what titles could be a fit for them.

In this 5-week workshop women will receive practical and theoretical instruction in a variety of skilled trades such as:

**Light Maintainers**  
**Power Distribution Maintainers**  
**Signal Maintainers**

**Dates to be Announced**

***Break with Traditional Titles***

**For more information, visit our website: [www.twulocal100tuf.org](http://www.twulocal100tuf.org)  
or  
Call TUF at 718-780-8700**

# ATTENTION TWU LOCAL 100 MEMBERS

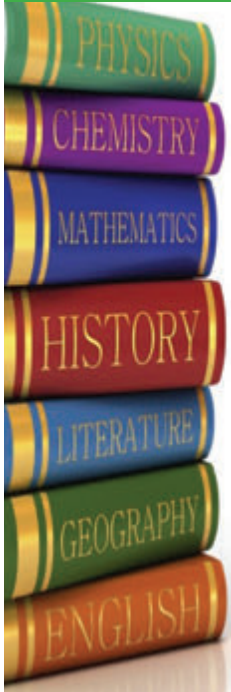

The beginning of a new school year is well on the way...  
Are you enrolled in **TUTOR.COM**?

Weather Basic Math, English, Social Studies,  
The Common Core Curriculum etc.

## TUTOR.COM CAN AIDE YOUR FAMILY AND YOURSELF!!

**TWU Local 100 &  
TWU Local 100 - NYCT Training & Upgrading Fund  
offers FREE on-line tutoring for your family and yourself.**

**FREE** Tutoring for your family and yourself, Anytime, Anywhere, from any computer, tablet, or mobile device.

### ALL SUBJECTS! ALL AGES! ALL LEVELS!

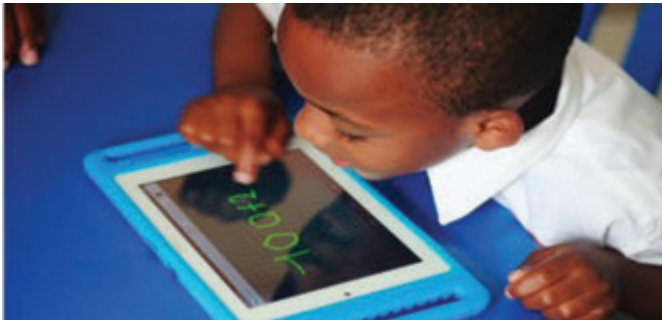

Personalized, live tutoring is now available for you and your children, **K-College. Five hours per month, completely free.**

(Tutor.com charges **\$2, 160** per year for the same 5hr per month benefit that you and your family are getting, **AT NO COST.**

**You and your family will now have access to the premier on-line educational website in the Country - Tutor.com - as your newest union benefit**

Sponsored By:



Students can work one-to-one in an online classroom with an expert tutor to:

- Complete homework
- Understand concepts in all subjects
- Study for exams

**SIMPLE AND EASY STEP:**

**REGISTER AT:**

[www.tutor.com/twulocaltuf](http://www.tutor.com/twulocaltuf)

Your USERNAME will be your  
Employee Pass # or ID number  
PASSWORD is twulocal100



# TUF OFFERS A PATH TO GREAT CAREERS IN TRANSIT

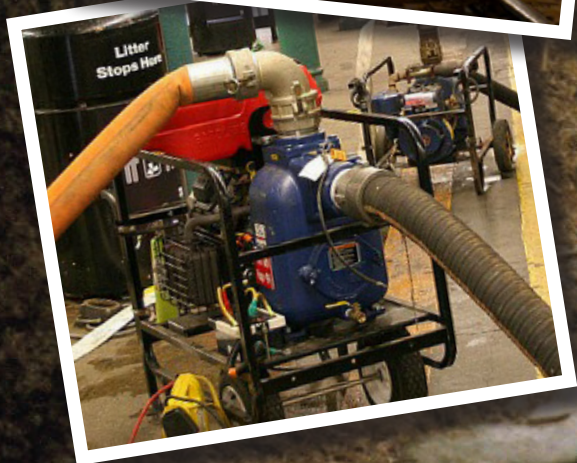



**Get Fit  
and Healthy  
with TUF.**

**NEW**  
**Nutritional Cooking and  
Fitness Classes**



**We all know we should eat right, but what does that mean? Eating right can help you maintain a healthy weight and avoid certain health problems but did you know that eating healthy is also about feeling great, having more energy and an improved outlook on life.**

**TUF classes will help you understand the basics of nutrition and healthy eating as well as the importance of exercise and fitness.**

**Call TUF to register for class at 718-780-8700**



# Registration Form

Name: \_\_\_\_\_ Pass #: \_\_\_\_\_ Date: \_\_\_\_\_

Address: \_\_\_\_\_ City: \_\_\_\_\_ State: \_\_\_\_\_ Zip: \_\_\_\_\_

Home Phone: \_\_\_\_\_ Cell/Alt Phone: \_\_\_\_\_

Email: \_\_\_\_\_ (Required)

Title: \_\_\_\_\_ Work Schedule/Tour: \_\_\_\_\_ RDO's: \_\_\_\_\_

Have you taken any other courses with TUF?  Yes  No

If yes, please list the courses you have taken: \_\_\_\_\_

\_\_\_\_\_

\_\_\_\_\_

If no, please tell us how you heard about our courses?  Mailing  Email Blast  Fax Blast

Union Rep  Co-Worker  Phone Call  Other: \_\_\_\_\_

TUF will use your contact information to communicate with you concerning upcoming courses, class cancellation, course reminders, and registration confirmations via text messages and emails. TUF will not share your information with any third parties.

Please use this form to submit your course selections. You may also use this form to submit any request for new classes that you may want to take. TUF will consider all request for new courses. If you have any questions, please feel free to reach out to us at 718-780-8700 from Monday through Friday between the hours of 9:00am to 5:00pm.

	Course	Borough/City	Day(s)	Start Time
1.				
2.				
3.				
4.				
5.				
6.				

Please fax form to: 718-222-1580 | Email: [training@twulocal100tuf.org](mailto:training@twulocal100tuf.org)  
Mail/Walk-in: 195 Montague Street, 4th Floor, Brooklyn, NY 11201



195 Montague Street  
4th Floor  
Brooklyn, NY 11201  
718-780-8700 tel  
718-222-1580 fax  
www.twulocal100tuf.org

Nonprofit Org.  
U.S. POSTAGE  
**PAID**  
Permit # 3978  
New York, NY

# Come build your career path with the Training & Upgrading Fund.

**And Much More!!**

**Check our website for upcoming  
courses and new benefits.**

**[WWW.twulocal100tuf.org](http://WWW.twulocal100tuf.org)**

