

TWU Local 100 – NYCTA
Training & Upgrading Fund

Spring

Catalog

2015

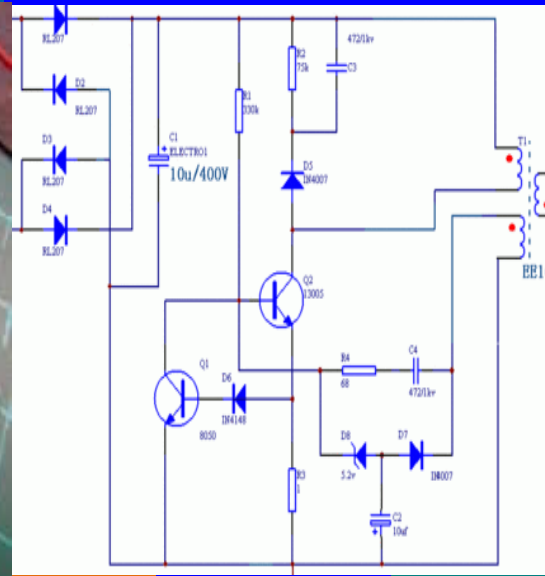

Auto Cad

Fiber Optics

Electronics

Promotional

Photovoltaic

Schematics

And Much More!



195 Montague Street, 4th Floor Brooklyn, NY 11201
 Phone: 718-780-8700 | Fax: 718-222-1580
 Email: training@twulocal100tuf.org
 Website: www.twulocal100tuf.org



Table of Contents

WORDS FROM THE DIRECTOR.....3
CALENDAR.....4
ELIGIBILITY/REGISTRATION.....5
COLLEGE PREPARATION.....6
HIGH SCHOOL EQUIVALENCY.....7
LANGUAGES.....8
COMPUTER SOFTWARE.....9
TECHNICAL COURSES.....12
GREEN CAREER CHOICES.....15
NON-TRADITIONAL EMPLOYMENT FOR WOMEN.....16
PROMOTIONAL OPPORTUNITIES.....17
PROFESSIONAL WORKSHOPS..... 18
FINANCIAL WORKSHOPS..... 21
ONLINE COURSES..... 22
REGISTRATION FORM..... 23

**TRAIN &
UPGRADE
YOUR
MIND!**



DOORS TO SUCCESS

It gives me great pleasure to be a part of such a wonderful community!

Here at TWU Local 100 – NYCTA Training and Upgrading Fund (TUF) we offer a wide range of training courses at little to no out of pocket cost to you. Whether you're looking to: upgrade to the highest level in your department, change to a different field within the NYCT, learn new languages, earn your High School Equivalency Diploma or complete your college degree- We have the programs to get you there.

Just in case you were wondering what courses would be the best for you, we have a highly trained staff that can assist you in choosing the courses that's right for you. We are committed to helping you with your career in keeping up with the ever changing technology in transportation.

Our doors are always open to you. Come visit us at 195 Montague Street 4th Floor Brooklyn, N.Y. 11201 or call us at (718) 780-8700 our office hours are 9:00am to 5:00pm.

I look forward to greeting you at the doors to success.

Charles Jenkins
Acting Director



Holiday Schedule

2015

Important Dates

1/1/2015	New Year's Day
1/19/2015	Martin Luther King Jr. Day
2/16/2015	President's Day
4/3/2015	Good Friday
4/5/2015	Easter
5/25/2015	Memorial Day

Notes:

Calendar is subject to change.

Not all holidays are observed by all sites.

January

S	M	T	W	T	F	S
				1	2	3
4	5	6	7	8	9	10
11	12	13	14	15	16	17
18	19	20	21	22	23	24
25	26	27	28	29	30	31

February

S	M	T	W	T	F	S
1	2	3	4	5	6	7
8	9	10	11	12	13	14
15	16	17	18	19	20	21
22	23	24	25	26	27	28

March

S	M	T	W	T	F	S
1	2	3	4	5	6	7
8	9	10	11	12	13	14
15	16	17	18	19	20	21
22	23	24	25	26	27	28
29	30	31				

April

S	M	T	W	T	F	S
				1	2	3
4	5	6	7	8	9	10
11	12	13	14	15	16	17
18	19	20	21	22	23	24
25	26	27	28	29	30	

May

S	M	T	W	T	F	S
					1	2
3	4	5	6	7	8	9
10	11	12	13	14	15	16
17	18	19	20	21	22	23
24	25	26	27	28	29	30
31						

June

S	M	T	W	T	F	S
	1	2	3	4	5	6
7	8	9	10	11	12	13
14	15	16	17	18	19	20
21	22	23	24	25	26	27
28	29	30				

Mission Statement

The TWU Local 100 - NYCTA Training & Upgrading Fund (TUF) will offer continuous education and training to the dedicated public transit workers who operate and maintain the largest system in the nation. It aims to enhance individual employability, growth, and opportunity. As the system modernizes, the Fund will help to ensure that workers keep pace with emerging technology. The Fund will give opportunities for workers to remain highly skilled, thus providing the best possible service and maximizing the value of the public investment in transportation.

Eligibility

Eligibility for TUF benefits depends upon the particular collective bargaining agreement or participation agreement covering your employment.

You are eligible to participate in TUF as soon as you become a Member of TWU Local 100 and an employee of a participating employer.

Limited classes are available for Retirees.

You are ineligible:

When you resign or are terminated from your position.

You are no longer an active member of TWU Local 100.

Your employer terminates its participation in the Plan.

The date Plan is terminated.

Registration

Every eligible member will have an equal opportunity to register for courses. Enrollment is done on a first come, first served basis for courses listed in this catalog.

Phone/Fax Registration

Please call 718-780-8700 or fax us at 718-222-1580

Email Registration

training@twulocal100tuf.org

Walk-in Registration

Hours: 9:00 am to 5:00 pm
195 Montague Street, 4th Floor,
Brooklyn, NY 11201.

Please note that classes may be canceled if enrollment is less than anticipated. All schedules are subject to change. Advance notice will be given.

Non-discrimination Policy

TUF admits eligible students of any race, color, national, or ethnic origin to all rights, privileges, and activities generally accorded or made available to members of the Fund. It does not discriminate on the basis of race, color, sexual orientation, national, or ethnic origin in administration of its educational policies, and other Fund administered programs.

Fostering an Environment for Learning

Members who take classes with TUF are hardworking people who are making big commitments to enhance their personal and professional careers. The complete Classroom Rules & Regulations regarding the logistics and what is expected of you during the operation of the course will be distributed at the beginning of each class. Members are also encouraged to remember to show their fellow classmates the respect they deserve by following the rules.

Attendance Policy

Regular attendance is mandatory. Depending on the length of your class, no more than three (3) absences are allowed for a certificate of completion. If you are more than one (1) hour late to any of your classes, you will be marked absent for the day ***and*** it will count towards your total allowed absences for the course.

Attendance requirements will be discussed in further detail in your class.

Class Prerequisites

Some classes will require you to complete a prerequisite class successfully before you are allowed to enroll. Some classes will require you to have minimum reading and math skills before you are allowed to enroll. If necessary, there will be an assessment test given soon after registration. If the class has a required prerequisite, it will be noted within the course description.

Emergency Closings

To find out if classes are canceled in the event of a weather emergency or other unsafe conditions, call 718-780-8700 or check our website at: www.twulocal100tuf.org for the latest information.

Please make sure TUF has your most current contact information on file.

Classroom Locations

BK1:

**TWU Local 100 - NYCTA Training & Upgrading Fund
195 Montague Street., 4th Floor, Brooklyn, N.Y. 11201**

BX1:

**1199 SEIU Training Center
2501 Grand Concourse, Bronx, N.Y. 10468**



English Review

English Review will provide a basic review of remedial english including grammar, sentence structure, punctuation, paragraph development, writing, etc. Members will complete many practice exercises and writing paragraphs.

Bk1: Wednesdays, 5:30pm to 8:30pm, 2/18/15 to 5/27/15

Bk1: Fridays, 9:30am to 12:30pm, 2/20/15 to 6/5/15

Math Review

Math Review will prepare members for the Transit Certificate Program (TCP) and college level courses. Topics include: basic math, scientific measurements, and algebra.

Bk1: Tuesdays, 5:30pm to 8:30pm, 2/17/15 to 5/26/15

Bk1: Thursdays, 9:30am to 12:30pm, 2/19/15 to 5/28/15

Technical Math

If you are looking to advance your career in electronics and/or electrical fields you need mathematics training. This course is designed to prepare members to understand the mathematics terminology in electronics and/or electrical. This course can also help prepare members for any Civil Service preparation exam. Topics include: decimals and fractions, ratios and proportions, unit conversions, area and volumes, application of algebraic equations in ohm's and kirchhoff's laws, solving for circuit resistance and reactions, relevant trigonometric functions, and use of graphs to analyze data.

BK1: Monday, 5:30pm to 8:30pm, 2/23/2015 to 6/8/2015

BK1: Wednesday, 9:30am - 12:30pm, 2/18/2015 to 5/27/2015

****Dates and times subject to change***



TEST
ASSESSING
SECONDARY
COMPLETION™

High School Equivalency (TASC)

A newly implemented exam called TASC (Test Assessing Secondary Completion) has replaced the GED. Members who began taking the GED test but did not complete all 5 modules will be required to retake the TASC test.

Some of the major changes to the test are:

- ☑ The test will be done on a computer.
- ☑ No writing utensils or hand-held calculators will be allowed into the test.
- ☑ The test will consist of five modules which are: Math, Reading, Writing, Science, and Social Studies.
- ☑ Test takers will receive detailed score reports in each area describing areas of mastery and/or areas in need of improvement.

Don't let the new changes to the GED/TASC Program discourage you. If you need to brush up on your computer skills, TUF has classes to help you.

Please contact TUF at 718-780-8700 if you are interested in enrolling in this course. Enrollment is done on a continuing basis.



Being able to communicate effectively with customers of diverse communities can be a great benefit for your employer when dealing with the public, emergency situations and providing essential services.

Transit Property Protection Agents, Traffic Checkers, Cleaners, Station Agents, Conductors, and Train Operators- Learn how to communicate more effectively with your diverse lingual customers!

You will learn the following skills:

- ☑ Developing conversational skills.
- ☑ Learning how to read and write in the language.
- ☑ Learning basic grammar tools.

Introduction to Spanish Level 1

Bk1: Mondays, 1:00pm to 4:00pm, 2/23/15 to 4/27/15

Bk1: Thursdays, 5:30pm to 8:30pm, 2/19/15 to 4/23/15

Bk1: Saturdays, 9:30am to 12:30pm, 2/21/15 to 5/2/15

English as a Second Language (ESL)

ESL is intended for those members wishing to improve their English Language skills. This course can help members participate in conversations with confidence. You will learn how to pronounce challenging vowels, consonants, and correct intonation. These skills will help your grammar and sentence structure when speaking and writing. This course is offered at the basic level.

Bk1: Mondays, 9:30am to 12:30pm, 2/2/15 to 4/13/15

BK1: Thursdays, 5:30pm to 8:30pm, 2/5/15 to 4/9/15

**Dates and times subject to change*

Introduction to Computers with Windows 8

This course focuses on the basics of the Introduction to Computers course, as well as introduces you to the new operating system of Windows 8. Microsoft has re-imaged and reinvented their new operating system. Come learn how to navigate and learn the new capabilities of the new Windows 8 user interface. Through hands-on practice, learn how to customize, navigate, explore, and utilize a Windows 8 operating system.

Bk1: Tuesdays, 9:30am to 12:30pm, 2/3/15 to 5/12/15

Bk1: Thursdays, 5:30pm to 8:30pm, 2/5/15 to 5/14/15

Bk1: Saturdays, 9:30am to 1:30pm, 2/21/15 to 5/30/15

Advanced Microsoft Word

Advanced Microsoft Word is a continuation course of Basic Microsoft Word. Members will learn advance formatting techniques such as tables, foot and end notes, creating envelopes and labels, mail merging, and protecting your document. By the end of this course you will be able to create, manage, revise, and secure your documents.

Bk1: Mondays, 9:30am - 12:30pm, 4/6/15 to 5/18/15

Bk1: Wednesdays, 5:30pm to 8:30pm, 4/1/15 to 5/13/15

Microsoft Word

Turn boring documents into must-read material. You will learn how to create professional documents such as letters, reports, memos, etc., through formatting tools, themes, designs, and sharing features.

**Bk1: Mondays, 9:30am to 12:30pm
2/9/15 to 3/30/15**

**Bk1: Wednesdays, 5:30pm to
8:30pm, 2/11/15 to 3/25/15**

Introduction to Computers

Come learn the basics of the computer. You will learn the best ways to navigate, organize, and manage your computer and its contents. You will identify parts of the computer and how they work, then move on to using basic programs and the Internet.

**Bx1: Tuesdays, 5:30pm to
8:30pm, 2/3/15 to 5/12/15**

**Bx1: Saturdays, 9:30am to
1:30pm, 2/21/15 to 5/30/15**

Computer Integration

Today's technology has an explosive growth in mobile and tablet devices. Mobile and Tablet devices play an essential role in both our personal and professional life. Most people rely on technology to help them operate more efficiently and effectively. TUF has a new course that can help members to utilize their smart phone or tablet like a Personal Computer on the Android Operating system. You will learn how to navigate keys, syncing email and social networks, print and email documents, and set up Wi-Fi.

Members must bring their own mobile and tablet devices!

Bk1: Monday, 10:00am to 4:00pm, 2/2/15

Bk1: Wednesday, 1:00pm to 7:00pm, 2/4/15

BK1: Saturday, 9:30am to 3:30pm, 2/7/15

Microsoft Excel

Turn unorganized data into usefule information. Excel is Microsoft's popular spread sheet application. Topics include entering data and formulas, moving and copying data, formatting & print previewing worksheets.

**Bk1: Mon., 5:30pm - 8:30pm;
2/2/15 - 3/23/15**

**Bk1: Wed., 9:30am - 12:30pm;
2/4/15 - 3/18/15**

Advance Microsoft Excel

Explore more advanced features of Microsoft Excel with this advanced course. This program features calculations, graphing tools, pivot tables, and macro programming language that simplifies techniques used for spreadsheets. You will organize data and create charts, graphs, and budgets.

Bk1: Mon., 5:30pm - 8:30pm; 3/30/15 - 5/11/15

BK1: Wed., 9:30am - 12:30pm; 3/25/15 - 5/6/15

**Dates and times subject to change*

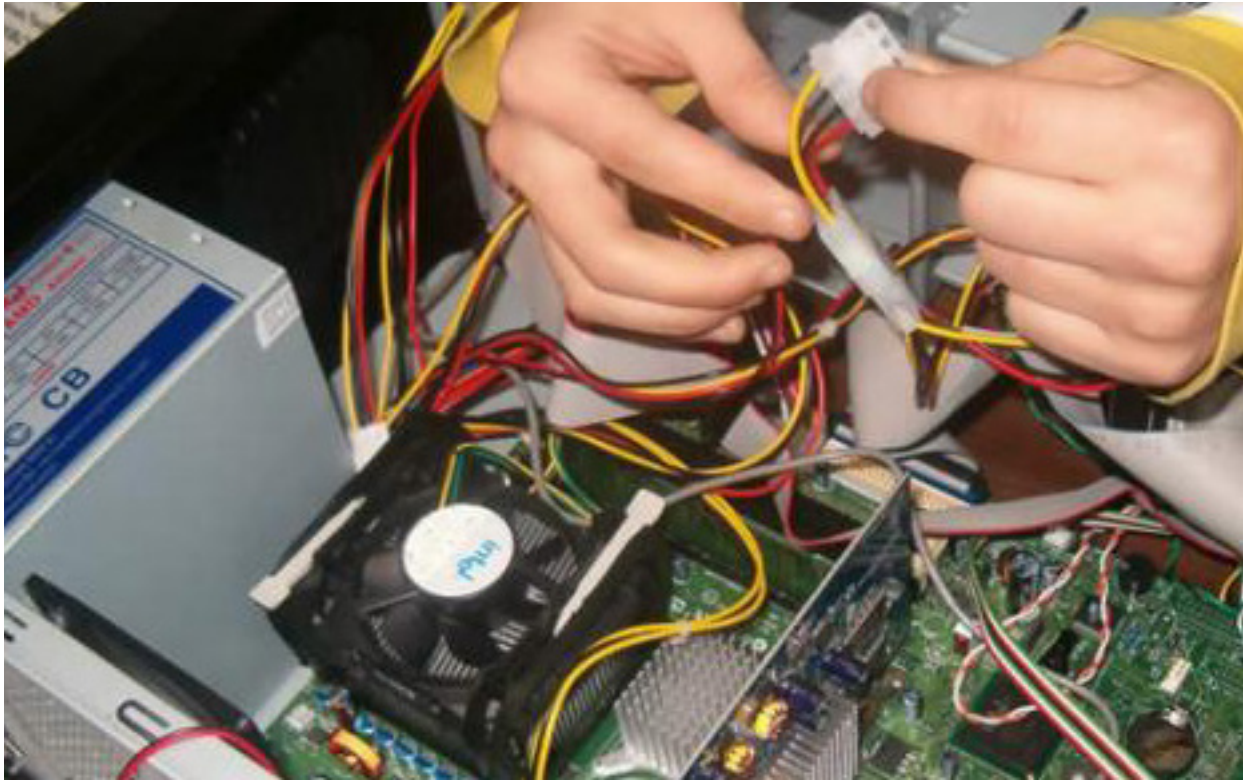

Computer Hardware 1

This course will introduce members to the basics of computer repair. Individually members will take apart and put together computers, install, and upgrade the operating system, analyze and clean-up the hard drive, and set up a simple network.

BK1: Tuesdays, 5:30pm to 8:30pm, 2/17/15 to 4/21/15

BK1: Wednesdays, 9:30am to 12:30pm, 2/18/15 to 4/22/15

Bk1: Thursdays, 5:30pm to 8:30pm, 2/19/15 to 4/23/15

Computer Hardware 2

This course will build on the knowledge acquired in Hardware 1. After a review of material from the previous course, emphasis will be placed on how the operating systems functions, how to customize your computer's environment, how to install MS Office, how to install and configure the software to protect your computer from viruses, spy-ware, and hackers, and how to restore your system to health after a catastrophe. ***Prerequisite required: Computer Hardware 1**

BK1: Mondays, 5:30pm to 8:30pm, 2/23/15 to 4/27/15

BK1: Saturdays, 9:30am to 12:30pm, 2/21/15 to 5/2/15

Electronics 1

You will learn the basic fundamentals of electronics terminology and mathematical formulas which will allow you to advance into other technical courses. Course content includes but is not limited to: Basic Electricity, D.C. and A.C. Electronics Theory, Semiconductor Theory, and Solid State Theory. ***Prerequisite required: You will be required to take a math assessment at the beginning of the course. If you do not pass, you will have to take a Math Review class before you will be allowed to take this course.**

BK1: Mondays and Tuesdays, 1:00pm to 4:00pm, 2/17/15 to 4/27/15

BK1: Tuesdays and Wednesdays, 5:30pm to 8:30pm, 2/17/15 to 4/22/15

BK1: Wednesdays and Thursdays, 9:30am to 12:30pm, 2/18/15 to 4/23/15

Electronics 2

You will build electronic projects with real electronic components. Each member will need to use the electronics theory that was applied in Electronics 1 and identify electronics components to complete each electronics project. Course contents include but is not limited to: Safety, Electronics Components Identification and Testing, and Project Board Writing. ***Prerequisite required: Electronics 1**

BK1: Mondays, 9:30am to 12:30pm, 2/23/15 to 6/8/15

BK1: Thursdays, 5:30pm to 8:30pm, 2/19/15 to 5/28/15



Schematics

In this class you will learn to identify the symbols that are schematically and pictorially used to represent various electrical components in an electrical circuit. You will learn how to accurately read and trace out simple and complex schematic circuits. You will be able to apply your knowledge of electrical and electronics theory to make use of schematic and wire diagrams to perform basic troubleshooting skills.

BK1: Mondays, 5:30pm to 8:30pm, 2/23/15 to 4/27/15

BK1: Tuesday, 9:30am to 12:30pm, 2/17/15 to 4/21/15

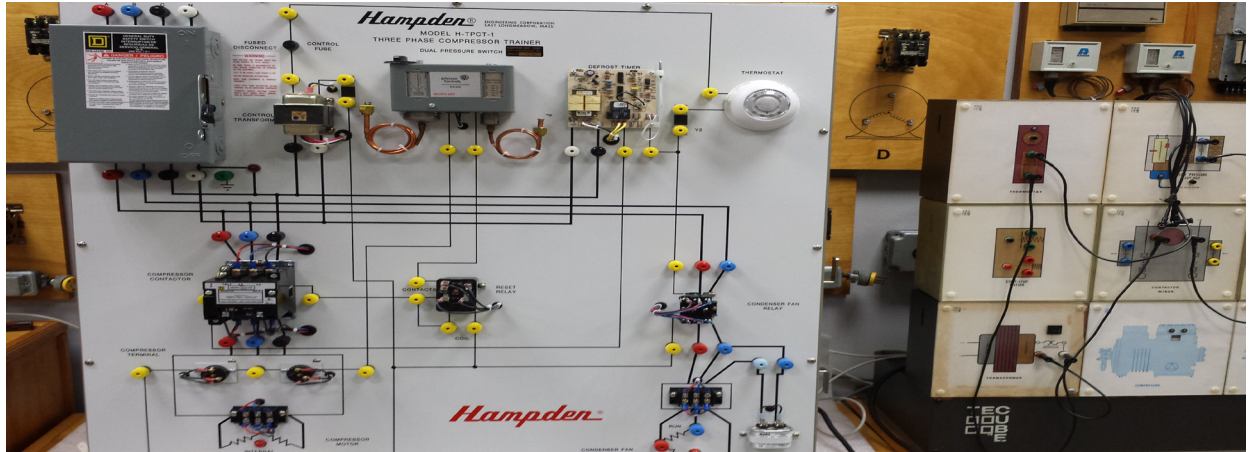

Auto-CAD

Auto-CAD is a computer-aided design and drafting software. This course will allow members to create two and three dimensional prototypes using step by step instruction and hands-on projects based on real-world designs. Topics will include the Auto-Cad drawing interface, display commands, CAD tools, and so much more! Members will master these concepts through the creation of a variety of 2d technical drawings. **Must have working knowledge of computers.**

BK1: Tuesdays, 5:30pm to 8:30pm, 2/3/15 to 5/26/15

BK1: Thursdays, 9:30am to 12:30pm, 2/5/15 to 5/28/15



Photovoltaics

This course will introduce members to PV component theory, system design, industry codes and standards, for PV systems, and unique design problems and solutions. ***Prerequisites required: Electronics 1**

BK1: Wednesday, 5:30pm - 8:30pm, 2/18/15 to 4/22/15

BK1: Fridays, 9:30am to 12:30pm, 2/20/15 to 5/1/15



Fiber Optics

This introductory fiber optics course is designed for anyone interested in learning basic fiber optic networking. This program combines theory and hands-on activities to prepare the student to take the CFOT (Certified Fiber Optics Technician) test. This course also introduces the student to industry standards, and further introduces the student to basic fusion and mechanical splicing. Anyone interested in becoming a Certified Fiber Optics Technician should attend this class. ***Prerequisite required: Electronics 1 or must have electronic knowledge and pass an assessment test.**

BK1: Mondays through Fridays, 9:30am to 1:30pm, 2/2/15 to 2/13/15

BK1: Mondays through Fridays, 5:00pm to 9:00pm, 2/2/15 to 2/13/15



TUF IS LOOKING FOR A FEW GOOD WOMEN!

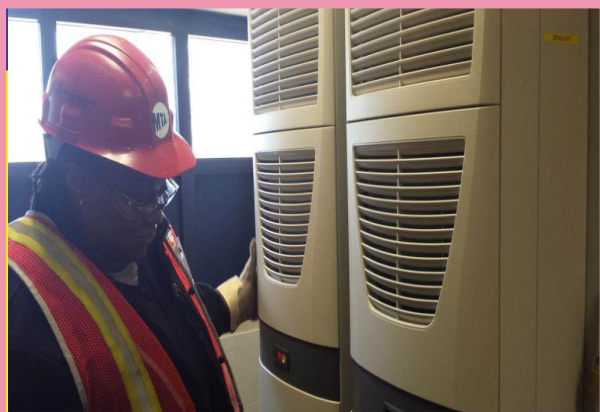

TUF wants to prepare, train, and place women in Non-Traditional Employment.

Are you interested in upgrading your career to one of the following titles?

- Car Inspector
- **Electronic Equipment Maintainer**
- Elevator & Escalator
- **HVAC**
- Light Maintainer
- **Mechanic**
- Revenue Equipment Maintainer
- **Signal Maintainer**
- Telephone Maintainer
- **Ventilation & Drainage Maintainer**

Call TUF for more information at
718-780-8700.



If so, these are the courses for you:

- Auto-CAD
- **Electronics**
- Fiber Optics
- **Photovoltaics**
- Schematics



Nontraditional Employment for Women

Transit Certificate Program (TCP)

Are you a Transit Property Protection Agent, Cleaner or Station Agent looking to climb the career ladder to Train Operator? The Transit Certificate Program is just for you. Members in entry level titles are now able to broaden their promotional opportunities. TCP gives members the background information they need to prepare for promotional exams in operational titles such as Train operator. TCP consists of three core courses and they are as follows:

- Worker, Health & Safety (3 college credits)**
- An Overview of Transit (3 college credits)**
- Job Duties of a Train Operator**

Successful completion of all three courses will make Civil Service members eligible to take the promotional exam for the Train Operator title. In addition, members can earn up to 6 college credits and can use them towards obtaining their degree.**

You will be required to take a TABE assessment test prior to entering these courses.

****Please check with your school to make sure they will accept these credits.**

BK1: Tuesday, 10:00am - 12:00pm, 6/2/2015

BK1: Thursday, 5:00pm - 7:00pm, 6/4/2015

BK1: Monday, 10:00am - 12:00pm, 6/8/2015

BK1: Wednesday, 5:00pm - 7:00pm, 6/10/2015

Civil Service Test Prep

NEW LAB FOR PRACTICALS IS HERE!

Have you filed for that Light Maintainer Exam but feel that you need to brush up on your test taking skills? Maybe your Tower Operator Exam is approaching and you would like to know a little more about the job? Our new hands-on laboratory can help you accomplish that and more! Prep courses are given for promotional exams that are within the TWU Local 100 Collective Bargaining Unit. Please call the Fund to inquire about Prep courses for any upcoming promotional exams.

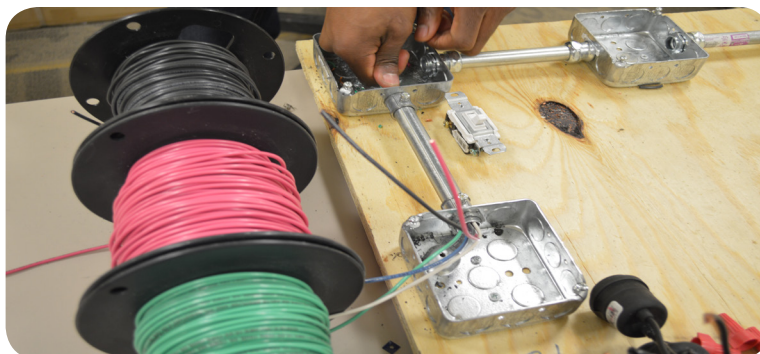

New York Defensive Driving

6-Hours Point and Insurance Reduction Course

New York State Defensive Driving Workshops eligible for:

All Active TWU Local 100 Brothers and Sisters.

\$20.00 Fee for MTA Bus, Private Lines, Retirees and Spouses

- Refresh your driving knowledge with a review of time-tested safe driving tips and an overview of today's New York State vehicle and traffic laws.
- Eligibility to reduce as many as four (4) points on your driving record.
- Receive a minimum 10% reduction in the base rate of your automobile and motorcycle liability and collision insurance each year for three years.

BK1: Mon/Tues, 5:00pm-8:00pm, 1/12/2015 - 1/13/2015

BK1: Thurs/Fri, 9:00am - 12:00pm, 1/15/2015 - 1/16/2015

BK1: Wed, 10:00am - 4:00pm, 1/21/2015

BK1: Sat, 10:00am - 4:00pm, 1/24/2015

BK1: Mon/Tues, 5:00pm-8:00pm, 2/9/2015 - 2/10/2015

BK1: Thurs/Fri, 9:00am - 12:00pm, 2/12/2015 - 2/13/2015

BK1: Wed, 10:00am - 4:00pm, 2/18/2015

BK1: Sat, 10:00am - 4:00pm, 2/21/2015

BK1: Sat, 10:00am - 4:00pm, 3/7/2015

BK1: Mon/Tues, 5:00pm - 8:00pm, 3/9/2015 - 3/10/2015

BK1: Thurs/Fri, 9:00am - 12:00pm, 3/12/2015 - 3/13/2015

BK1: Wed, 10:00am - 4:00pm, 3/18/2015

BK1: Mon/Tues, 5:00pm - 8:00pm, 4/13/2015 - 4/14/2015

BK1: Thurs/Fri, 9:00am - 12:00pm, 4/16/2015 - 4/17/2015

BK1: Sat, 10:00am - 4:00pm, 4/18/2015

BK1: Wed, 10:00am - 4:00pm, 4/22/2015

BK1: Sat, 10:00am - 4:00pm, 5/9/2015

BK1: Mon/Tues, 5:00pm - 8:00pm, 5/11/2015 - 5/12/2015

BK1: Thurs/Fri, 9:00am - 12:00pm, 5/14/2015 - 5/15/2015

BK1: Wed, 10:00am - 4:00pm, 5/20/2015

BK1: Mon/Tues, 5:00pm - 8:00pm, 6/8/2015 - 6/9/2015

BK1: Thurs/Fri, 9:00am - 12:00pm, 6/11/2015 - 6/12/2015

BK1: Sat, 10:00am - 4:00pm, 6/13/2015

BK1: Wed, 10:00am - 4:00pm, 6/17/2015

**Dates and times subject to change*



CPR/First Aid/AED

Our hands-on First Aid/CPR/AED course will prepare you to respond to a variety of emergencies for adults and children through lectures, interactive videos, emergency scenarios, and hands-on training.

You will learn to:

- Call for and work with EMS.
- Care for a variety of emergencies such as burns, cuts and scrapes, sudden illness, head, neck, and back injuries, etc...
- Care for conscious and unconscious victims.
- Perform CPR and care for breathing and cardiac emergencies in adults and children.
- Learn how to use automatic external defibrillator's.
- Gain confidence to act quickly and effectively in the face of an emergency.

Once the course is completed you will receive a First Aid/CPR/AED certification.

You should get re-certified every two years.

- BK1: Monday, 12:00pm - 6:00pm, 1/26/2015**
- BK1: Saturday, 10:00am - 4:00pm, 1/31/2015**
- BK1: Saturday, 10:00am - 4:00pm, 2/21/2015**
- BK1: Wednesday, 12:00pm - 6:00pm, 2/25/2015**
- BK1: Saturday, 10:00am - 4:00pm, 3/14/2015**
- BK1: Monday, 12:00pm - 6:00pm, 3/16/2015**
- BK1: Saturday, 10:00am - 4:00pm, 4/25/2015**
- BK1: Wednesday, 12:00pm - 6:00pm, 4/29/2015**
- BK1: Saturday, 10:00am - 4:00pm, 5/16/2015**
- BK1: Monday, 12:00pm - 4:00pm, 5/18/2015**
- BK1: Saturday, 10:00am - 4:00pm, 6/20/2015**
- BK1: Wednesday, 12:00pm - 6:00pm, 6/24/2015**



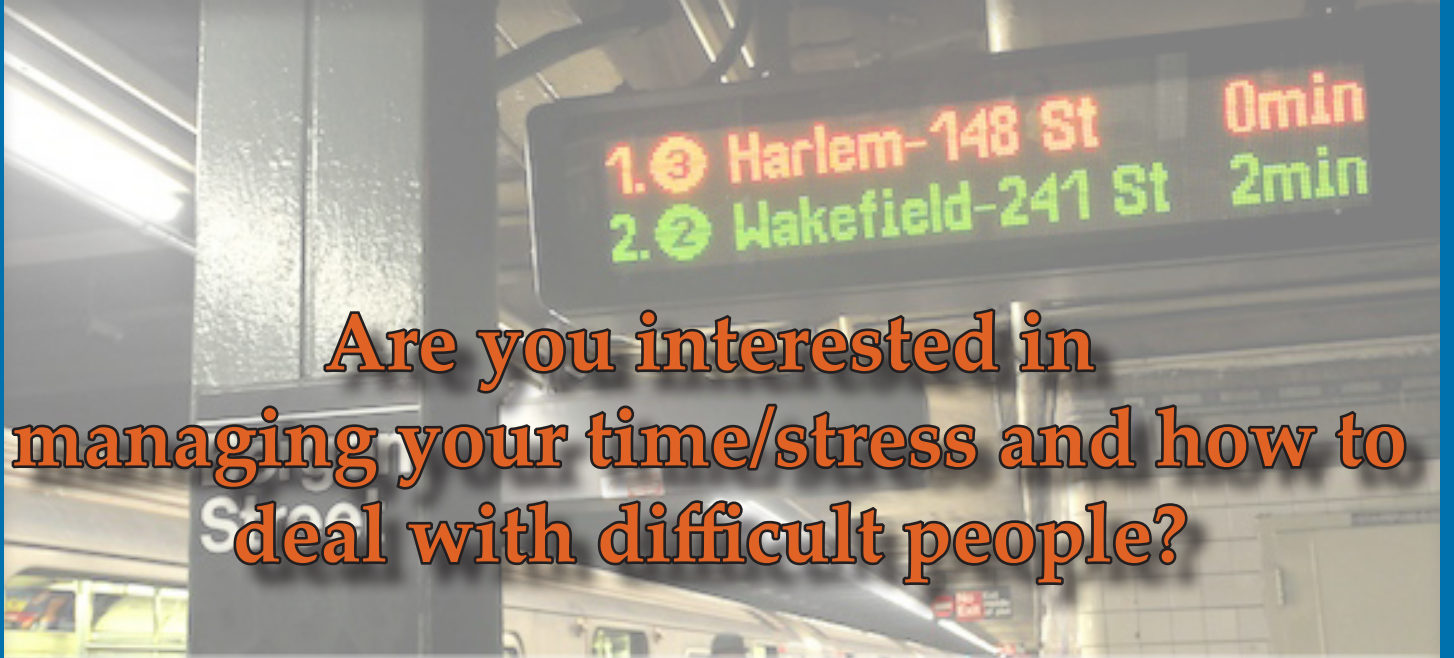

**Are you interested in
managing your time/stress and how to
deal with difficult people?**

***If so, we have the
perfect workshops for you!***

Time Management

Members will learn techniques on how to manage time more efficiently and effectively.

Stress Management

Members will learn strategies and techniques on how to deal with stressful situations.

Dealing with Difficult People

Members will learn concrete techniques for dealing with difficult people in and out of the workplace. Learn how to get chronic complainers to quiet down and difficult people to cooperate.

Call us at 718-780-8700 today!

Isn't it time to make your money work for you?

These workshops are for members who want to understand how money works, how to plan for their financial future, and secure their life goals and dreams.

Learn how to manage your finances and credit score.

Psychology of Money/Behavioral Finance

- BK1: Tuesday, 5:00pm - 7:00pm, 2/3/2015
- BK1: Wednesday, 1:00pm - 4:00pm, 2/11/2015
- BK1: Thursday, 10:00am - 12:00pm, 2/19/2015

Taxes and Tax Credit

- BK1: Tuesday, 5:00pm - 7:00pm, 3/3/2015
- BK1: Friday, 10:00am - 12:00pm, 3/20/2015
- BK1: Wednesday, 1:00pm - 4:00pm, 3/25/2015

Credit, Credit Reports and Debt

- BK1: Wednesday, 10:00am - 12:00pm, 4/8/2015
- BK1: Tuesday, 5:00pm - 7:00pm, 4/21/2015
- BK1: Thursday, 10:00am - 12:00pm, 4/30/2015

Buying a Home and Foreclosure Prevention

- BK1: Tuesday, 5:00pm - 7:00pm, 5/5/2015
- BK1: Friday, 10:00am - 12:00pm, 5/22/2015
- BK1: Wednesday, 1:00pm - 4:00pm, 5/27/2015

Investments, Insurance, and Retirement Planning

- BK1: Wednesday, 1:00pm - 4:00pm, 6/3/2015
- BK1: Tuesday, 5:00pm - 7:00pm, 6/16/2015
- BK1: Thursday, 10:00am - 12:00pm, 6/18/2015

**Dates and times subject to change*

New Jersey Online Defensive Driving

Online Point & Insurance Reduction course

All Active NJ Licensed TWU Local 100-NYCTA Members are eligible to participate!

- Defensive driving course may be used to remove 2 points from driving records.
- Defensive Driving course provides a minimum 5% reduction in the base rate of your liability, no-fault, and collision premiums. Some insurance companies offer more!



Take
Your
Driving
Class
Online

-This course is free to Active TWU Local members that are employed by NYC Transit and MaBSTOA.

-Refresh your driving knowledge and receive new tips on driving safely and car maintenance.

In order to take the class, you must have a valid email address and you must register with TUF before taking this class. TUF will not be responsible for members who take the class on their own without registering with us first!





Registration Form

Name: _____ **Pass #:** _____ **Date:** _____
Address: _____ **City:** _____ **State:** _____ **Zip:** _____
Home Phone: _____ **Cell/Alt Phone:** _____
Email: _____
Title: _____ **Work Schedule/Tour:** _____ **RDO's:** _____

Have you taken any other courses with TUF? Yes No
 If yes, please list the courses you have taken: _____

 If no, please tell us how you heard about our courses? Mailing Email Blast Fax Blast
 Union Rep Co-Worker Phone Call Other: _____

Please use this form to submit your course selections. You may also use this form to submit any request for new classes that you may want to take. TUF will consider all request for new courses. If you have any questions, please feel free to reach out to us at 718-780-8700 from Monday through Friday between the hours of 9:00am to 5:00pm.

	Course	Borough/City	Day(s)	Start Time
1.				
2.				
3.				
4.				
5.				
6.				
7.				
8.				

Please fax form to: 718-222-1580
 Email: training@twulocal100tuf.org
 Mail/Walk-in: 195 Montague Street, 4th Floor, Brooklyn, NY 11201



195 Montague Street
4th Floor
Brooklyn, NY 11201
718-780-8700 tel
718-222-1580 fax
www.twulocal100tuf.org

Preparing for the future today!

DETERMINED



TALENTED



UNITED

